



FORWARD TECHNOLOGY

a Crest Group Company



(shown with optional features)

HS-OSW

High Speed Orientation (Servo Motor) Spin Welder

The HS-OSW is a high speed pneumatic motion controlled orientation (servo motor) spin welder designed for smaller diameter, more difficult spin welding applications requiring delivery of high rotational speed while maintaining the highest degree of precision. This servo drive spin welder is capable of orienting part halves relative to each other with a positioning accuracy of +/- 0.5°. Exact start (home) and stop (final orientation) points can be programmed and precisely controlled.

When compared to non-orientation models, orientation (servo motor) systems typically:

- Permit precise orientation/alignment of part halves relative to one another.
- Allow precise depth welding (collapse distance or absolute distance) when orientation is not required.
- Enable welding of smaller parts with more difficult to weld materials.
- Are much easier to automate as the driver rotational position may be precisely programmed between welding cycles, allowing easier loading of the upper part half into the driver.

Standard Features

- **Ultra-Rigid Rectangular Column** minimizes deflection of the system under even the highest pressures.
- **Modular Design** allows adaptability to a variety of production configurations. Controller height may be repositioned or removed from the press and relocated to a user preferred position.
- **Servo-Electric Drive/Amp 0 - 7,000 RPM Motor** ensures precise rotational positioning.
- **5.7" VGA Color Touch-Screen User Interface with Integral Programmable Operator Control Station** simplifies parameter input and allows the following to be displayed:
 - RPM / Weld Mode / Weld Distances (Collapse & Absolute) / Hold Time / Pressures
 - Resettable Parts Counter
 - Total Machine Cycle Counter
 - Micro-SD Memory Card Slot (Slot to support use of up to 32G Flash Memory Card)
 - Ethernet Connectivity
- **Precision Linear Stroke Encoder** allows welding by Collapse and Absolute Distance and/or alarm monitoring of these values.
- **Weld by Revolutions (Orientation) or Time, Collapse Distance, or Absolute Distance (Non-Orientation)** allows the user enhanced control for applications requiring precise welding.
- **Time, Collapse Distance, and Absolute Distance Pass/Fail Windows** allow the user to set min/max alarm limits for bad parts for quality control purposes.
- **Multi-Level Passcode Protection** limits parameter adjustment to qualified personnel only.
- **5 Weld Program/Setup Memory** allows storage for instant recall, minimizing tool change time.
- **Dual Speed Vertical Head Velocity Control with Proportional Valve for Pneumatic Pressure Control** allows user to program individual settings for initial part approach speed, contact pressure, weld pressure, and cooling pressure in passcode protected memory. Reduces cycle times and improves repeatability.
- **3.9" (100mm) Actuator Stroke** permits part loading/unloading with adequate hand clearance while keeping actuator stroke at a minimum to optimize process control as required for smaller, delicate applications.
- **1.6" (40mm) Diameter Pneumatic Cylinder** provides finesse yet ample force for most spin welding applications.
- **Spin Initiation (Trigger) by Height with Programmed Delay-Time** simplifies set-up. No limit switches to adjust when changing part height. Head-Down step used to "teach" system target part height. System retains learned height setting in programmed memory.
- **Zero Force Cycle Activation Switches** reduce operator fatigue.
- **Lockable Mechanical Stop** prevents shift/migration of stop setting in even the worst vibrating environments.
- **Built-In User Inputs/Outputs** allow integration of part clamping and/or part presence sensors. Permits external start/stop command functions by customer PLC if used in automation.

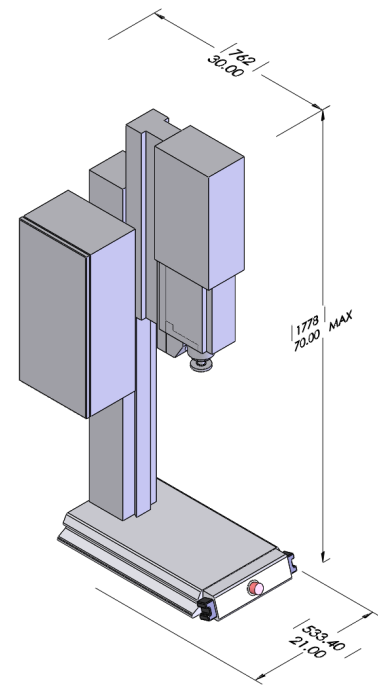

MECHANICAL SPECIFICATIONS

Weight:	~350 lbs (159kg)
Machine:	30.0" D x 21.0" W x 70.0" H (762mm x 533mm x 1778mm)
Actuator Stroke:	3.9" (100mm)
Driver Hub to Base Height Adjustment Range:	0.0" – 29.0" (0mm – 737mm)
Throat Depth (Center of Driver to Column Front):	10.5" (267mm)

PERFORMANCE SPECIFICATIONS

Maximum Motor Speed:	7,000 RPM
Maximum Motor Power:	0.93kW (7,000 RPM)
Maximum Driver Weight:	1.0 lbs (0.45kg)
Maximum Clamp Force:	155 lbs @ 80.0 PSI (0.69kN @ 5.5 Bar)
Warranty:	2 Years (Parts & Service)

OPERATING REQUIREMENTS

Electrical Requirements:	240VAC, 1PH, 20A, 60Hz
Pneumatic Requirements:	80 PSI, 0.375" ID (5.5 Bar, 10mm ID) Supply Line

Optional Features

- Special Energy Star Compliant Operating Voltages Transformer
- Expanded Input/Output Module
- Welded Tubular Steel Support Frame with Leveling Feet
- Light Screen Safety Protection
- Pneumatic Powered Safety Door
- Leveling Casters
- LED Four Color Light Tower
- External Lighting
- Fixture Clamp Valve(s)
- Tooling Sensor(s)
- Remote Access Connection Router
- Data Acquisition Program
- Compressed Air Reserve Tank



260 Jenks Ave. SW
Cokato, Minnesota 55321
Phone: 320.286.2578
Fax: 320.286.2467
info@forwardtech.com
www.forwardtech.com