



FORWARD TECHNOLOGY

a Crest Group Company



(shown with optional features)

HH-1232

Horizontal Hydraulic Hot Plate Welder

The HH-1232 is a horizontal heat platen orientation, hydraulic motion controlled hot plate welding system capable of welding parts up to 12" x 32" (305mm x 813mm) or multiple smaller parts. Customized variants of this model are available.

When compared to vertical platen systems, horizontal systems typically:

- Are much better suited for part designs where internal components are loose inside one part half prior to welding.
- Allow easier loading of both part halves together into lower tool (requires part-part alignment features) using automatic pick-up of upper part half by upper tool.
- Allow the option of loading and unloading parts outside the machine (using optional power or manual lower tool carriage/drawer and automatic pick-up of upper part half).

Standard Features

- **Ultra-Rigid Construction** utilizing a tubular steel framework with leveling feet and linear guide shafts & bearings designed for precise tool alignment through decades of use.
- **Hydraulic System with Proportional Valve Control and Linear Position Transducers** offers improved control and reduced machine and coating wear by user programmed variable tool mounting jaws and heat platen carriage pressures and speeds, including "soft-touch" contact of part halves to heat platen (Melt) and each other (Weld/Seal).
- **Digital Two-Zone Temperature Control via PLC with Heater Burnout Alarm** ensures even heating and precise temperature control with temperature alarm limits. Burnout alarm halts operation of the machine in the event of platen heater failure.
- **Programmable Automatic Machine and Heat Platen Startup (Time/Date Based)** saves production time as the machine can be user programmed to automatically initialize warm-up of heat platen and hydraulic system before start of production.
- **Allen Bradley CompactLogix PLC with PanelView Plus 7 - 700 Color 6.5" Touch-Screen Graphical Display** simplifies parameter input and allows the following to be displayed:
 - Melt, Weld (Seal), & Open Time Digital Control & Display
 - Resettable Parts Counter
 - Non-Resettable Total Machine Cycle Counter
 - Diagnostic Display
 - Machine Alarms (history storage of up to 99 alarms)
 - Ethernet Connectivity
- **Multi-Level Passcode Protection** limits parameter adjustment to qualified personnel only.
- **25 Weld Program/Setup Memory** allows storage for instant recall, minimizing tool change time.
- **External 120VAC Duplex Electrical Outlet** allows user to easily connect small auxiliary equipment such as computers, printers, radios, etc.
- **Dual Venturi 25.0 in/Hg (63.5cm/Hg) Vacuum Pump System** designed to secure even the largest parts within the tooling.
- **Pneumatic Power Sliding Door with Safety Tapeswitch & Zero Force Cycle Activation Switch** provides optimum personnel protection while reducing operator fatigue.
- **Hinged Access Panels with Safety Interlock Switches** allow extensive access while providing maximum personnel protection.
- **Vent Hood with Exhaust Fan** evacuates airborne smoke and particulate from the operator location when welding at high temperatures without coatings.

Optional Features

- Air/Pneumatic (HA) Operation
- Special Energy Star Compliant Operating Voltages
- Manual/Powered Lower Tool Carriage/Drawer
- Additional Temperature Control Zone with Heater Burnout Alarm
- Larger Operator Interface
- LED Four Color Light Tower
- External Lighting
- Light Curtains
- Fork Lift Tubes
- Leveling Casters
- Quick Disconnect Outlets & Sensors
- Heat Platen & Tooling Fixture Storage Cart with Casters

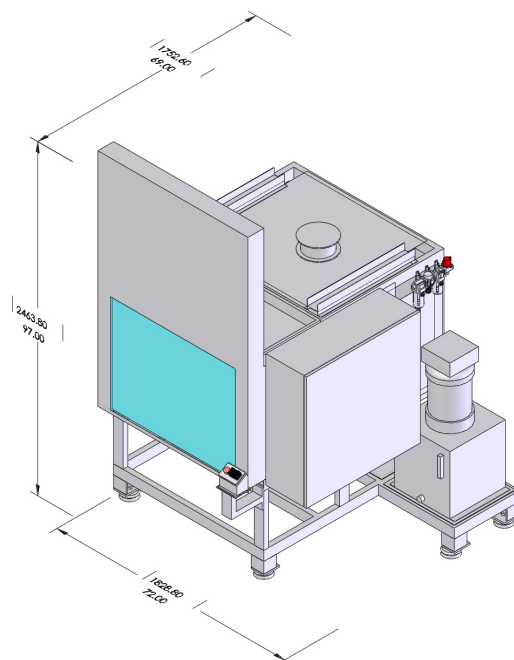

MECHANICAL SPECIFICATIONS:

Weight:	~3500 lbs (1588 kg)
Overall Dimensions:	69.0" D x 72.0" W x 97.0" H (1753mm x 1829mm x 2464mm)
Maximum Heat Platen:	12.0" x 32.0" (305mm x 813mm)
Heat Platen Carriage Stroke (back-front):	15.0" (381mm)
Heat Platen Assembly Lateral Stroke (top-bottom):	3.0" (76mm)
Tool Mounting Jaws:	14.5" x 34.5" (368mm x 876mm)
Daylight Opening (between Tool Mounting Jaws):	17.0" (432mm)
Tool Mounting Jaw Stroke:	12.0" (305mm)
Front Door Opening:	39.5" W x 31.0" H (1003mm x 787mm)

PERFORMANCE SPECIFICATIONS:

Moving Tool Mounting Jaw:	Single - Upper
Hydraulic System:	7.5 HP, 1750 RPM, 7.0 GPM (5.6kW, 1750 RPM, 26.5 LPM) 1000 PSI (68 Bar) Max. Pressure
Total Clamp Force:	1760 lbs @ 1000 PSI (7.83kN @ 68 Bar)
Dual Venturi Vacuum System:	25.0 in/Hg (63.5cm/Hg)
Thermal Temperature Range:	100°F - 1000°F (38°C - 538°C) Tooling and Application Dependent
Warranty:	1 Year (Parts & Service)

SYSTEM REQUIREMENTS:

Electrical Requirements:	480VAC, 3PH, 60 Hz
Pneumatic Requirements:	80 PSI, 0.75" ID (5.5 Bar, 19mm ID) Supply Line

System includes Filter/Regulator/Lubricator



260 Jenks Ave. SW
Cokato, Minnesota 55321
Phone: 320.286.2578
Fax: 320.286.2467
info@forwardtech.com
www.forwardtech.com