



FORWARD TECHNOLOGY

a Crest Group Company



(shown with optional features)

ESVH-1015

Extended Stroke Vertical Hydraulic Hot Plate Welder

The ESVH-1015 is an extended stroke, vertical heat platen orientation, hydraulic motion controlled hot plate welding system capable of welding parts up to 10" x 15" (254mm x 381mm) or multiple smaller parts. Customized variants of this model are available.

When compared to horizontal platen systems, vertical systems typically:

- Allow faster tooling changeovers.
- Allow easier and more positive operator loading and unloading of the tooling.
- Ensure more precise part half alignment during welding (less scrap) as no special part-part alignment features must be designed into the parts themselves (required for accurate machine pick-up of one part half on horizontal systems).

Standard Features

- **Ultra-Rigid Construction** utilizing a tubular steel framework with leveling feet and linear guide shafts & bearings designed for precise tool alignment through decades of use.
- **Hydraulic System with Proportional Valve Control and Linear Position Transducers** offers improved control and reduced machine and coating wear by user programmed variable tool mounting jaws and heat platen carriage pressures and speeds, including "soft-touch" contact of part halves to heat platen (Melt) and each other (Weld/Seal).
- **Digital Single-Zone Temperature Control via PLC with Heater Burnout Alarm** ensures even heating and precise temperature control with temperature alarm limits. Burnout alarm halts operation of the machine in the event of platen heater failure.
- **Programmable Automatic Machine and Heat Platen Startup (Time/Date Based)** saves production time as the machine can be user programmed to automatically initialize warm-up of heat platen and hydraulic system before start of production.
- **Allen Bradley CompactLogix PLC with PanelView Plus 7 - 700 Color 6.5" Touch-Screen Graphical Display** simplifies parameter input and allows the following to be displayed:
 - Melt, Weld (Seal), & Open Time Digital Control & Display
 - Resettable Parts Counter
 - Non-Resettable Total Machine Cycle Counter
 - Diagnostic Display
 - Machine Alarms (history storage of up to 99 alarms)
 - Ethernet Connectivity
- **Multi-Level Passcode Protection** limits parameter adjustment to qualified personnel only.
- **25 Weld Program/Setup Memory** allows storage for instant recall, minimizing tool change time.
- **External 120VAC Duplex Electrical Outlet** allows user to easily connect small auxiliary equipment such as computers, printers, radios, etc.
- **Dual Venturi 25.0 in/Hg (63.5cm/Hg) Vacuum Pump System** designed to secure even the largest parts within the tooling.
- **Pneumatic Dual Power Sliding Safety Doors with Zero Force Cycle Activation Switch and Door Safety Tapeswitch** provide optimum personnel protection while reducing operator fatigue.
- **Hinged Access Panels with Safety Interlock Switches** allow extensive access while providing maximum personnel protection.
- **Vent Hood with Exhaust Fan** evacuates airborne smoke and particulate from the operator location when welding at high temperatures without coatings.

Optional Features

- Air/Pneumatic (ESVA) Operation
- Special Energy Star Compliant Operating Voltages
- Additional Temperature Control Zone with Heater Burnout Alarm
- Larger Operator Interface
- Customized PLC Programming
- LED Four Color Light Tower
- External Lighting
- Light Curtains
- Fork Lift Tubes
- Leveling Casters
- Quick Disconnect Outlets & Sensors
- Heat Platen & Tooling Fixture Storage Cart with Casters
- Pre-Heat Temperature Zone Station

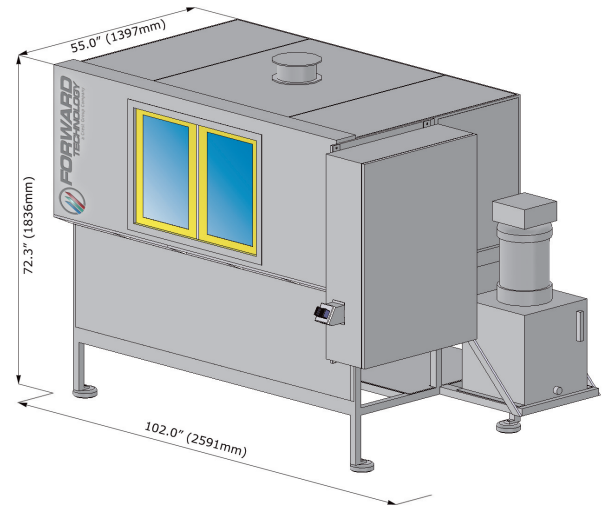

MECHANICAL SPECIFICATIONS:

Weight:	~2250 lbs (1021kg)
Overall Dimensions:	55.0" D x 102.0" W x 72.3" H (1397mm x 2591mm x 1836mm)
Maximum Heat Platen:	10.0" D x 15.0" H (254mm x 381mm)
Heat Platen Carriage Stroke (back-front):	12.0" (305mm)
Heat Platen Assembly Lateral Stroke (side-side):	1.5" (38mm)
Tool Mounting Jaws:	10.0" D x 15.0" H (254mm x 381mm)
Daylight Opening (between Tool Mounting Jaws):	30.0" (762mm)
Tool Mounting Jaw Stroke (each):	12.0" (305mm)
Front Door Opening:	32.0" W x 23.8" H (813mm x 605mm)

PERFORMANCE SPECIFICATIONS:

Moving Tool Mounting Jaws:	Dual - Left and Right
Hydraulic System:	5.0 HP, 1750 RPM, 10.0 GPM (3.73kW, 1750 RPM, 37.9 LPM) 1000 PSI (68 Bar) Max. Pressure
Maximum Clamp Force:	1776 lbs @ 1000 PSI (7.90kN @ 68.0 Bar)
Dual Venturi Vacuum System:	25.0 in/Hg (63.5cm/Hg)
Thermal Temperature Range:	100°F - 1000°F (38°C - 538°C) Tooling and Application Dependent
Warranty:	1 Year (Parts & Service)

SYSTEM REQUIREMENTS:

Electrical Requirements:	480VAC, 3PH, 60 Hz
Pneumatic Requirements:	80 PSI, 0.5" ID (5.5 Bar, 13mm ID) Supply Line

System includes Filter/Regulator/Lubricator



FORWARD
TECHNOLOGY
a Crest Group Company

260 Jenks Ave. SW
Cokato, Minnesota 55321
Phone: 320.286.2578
Fax: 320.286.2467
info@forwardtech.com
www.forwardtech.com